

SUMITOMO

P A V E R S

Sumitomo Asphalt Paver
Jpaver
HA90C-2(B)



 **SUMITOMO (S.H.I.)
CONSTRUCTION MACHINERY CO., LTD.**

731-1 Naganumahara-cho, Inage-ku, Chiba, 263-0001 Japan

For further information please contact:

Phone : +81-43-420-1829 Facsimile : +81-43-420-1907

<http://www.sumitomokenki.com/>

We are constantly improving our products and therefore reserve the right to change designs and specifications without notice.
Illustrations may include optional equipment and accessories and may not include all standard equipment.

TRANSITION TO A NEW STAGE

Paving the way. With our way.

SUMITOMO Pavers are designed under the concept of the following 3 points and manufactured with high quality.

- **Human Friendly**
 - **Eco Friendly**
 - **Repair Friendly**
- High Performance**
Easy Operation
Cost and Time Saving

J-paver



Paving width can be adjusted from 2.8 m -7.5 m by just the flick of a switch (paving up to 9.0 m wide)

Photo of 9.0 m width (maximum paving width)
Photo may include optional equipment



Photo of 7.5 m width
Photo may include optional equipment

[Crawler Type]
HA90C-2
 EU Stage III A / EPA Tier 3
HA90C-2B
 EU Stage III B / EPA Interim Tier 4

HA90C-2B is equipped with DPD and complies with EU Stage III B exhaust gas emissions standards

Diesel Particulate Diffuser (DPD)

DPD is an exhaust after treatment device which traps and burns off PM in the exhaust gas. PM accumulation can be monitored by the DPD status gauge, and Auto Regeneration (filter cleaning) will be conducted at regular intervals.

DPD Structural Overview

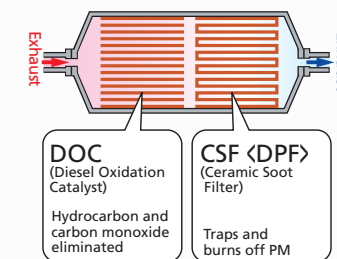

Monitor Display (DPD gauge)



High-power torque and low fuel consumption engine

The power system, a combination of an intelligent **ISUZU** engine and **SUMITOMO's** cutting-edge technology, delivers high work efficiency and low fuel consumption.



Engine system; ISUZU-4HK1X
Common rail fuel injection system

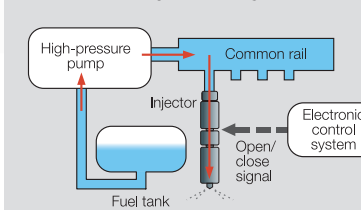

Cooled EGR system

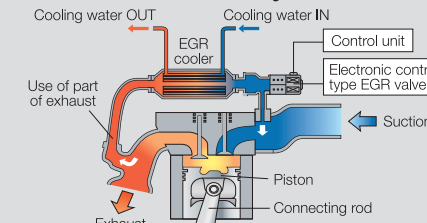

4-valve DOHC turbo engine with intercooler

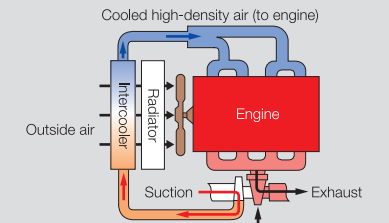

World First: The Extendable Screed Brings Drastic Time Savings and Cost Reductions.

The infinitely variable triple screed can be used for 2.8~7.5 m widths

World first

Selectable Screed



Photo may include optional equipment

Two-lane paving

The J-paver2875 can pave two lanes of high specification road without any bolt-on extension screed.

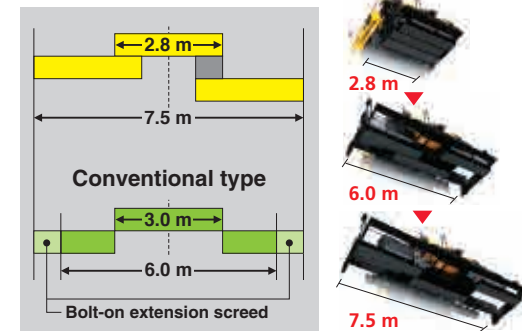
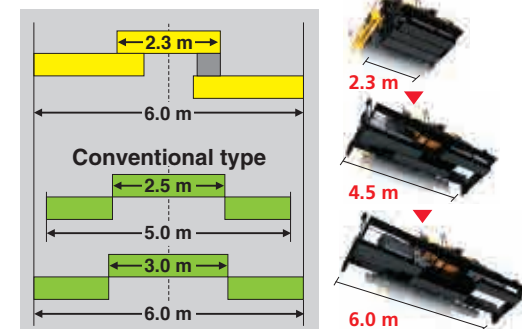

Photo may include optional equipment

Double role

The J-paver2360 covers two conventional screed ranges.



Bolt-on extension screed (750 mm)

Larger width through the addition of bolt-on extensions up to a maximum 9.0 m.

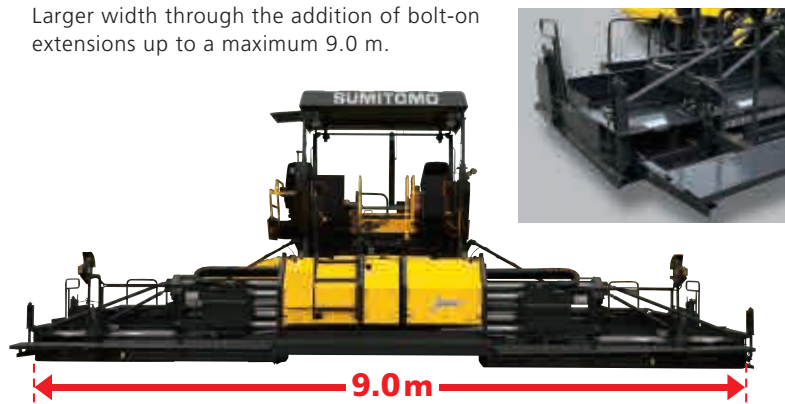

Photo of 9.0 m width (maximum paving width)
Photo may include optional equipment

Easy transportation

The HA90C can transport the following width without removing the side plate.

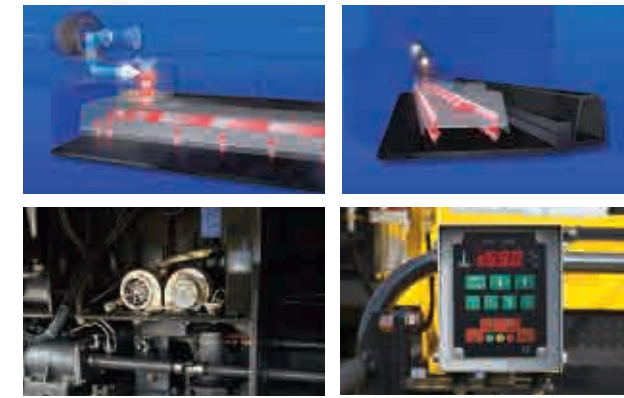

Photo may include optional equipment

Human-friendly

LPG Blower burner (Auto. Temp control type)

The heating controller keeps the temperature of each screed to the setting temp automatically.



Electric heating system (option)

Sumitomo's latest control system delivers ecologically optimized heating without increasing the horsepower of the engine.

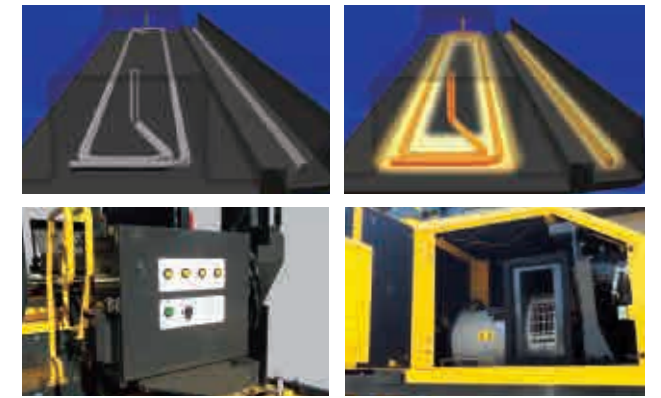

Height of extendable screeds

When a difference in surface height occurs between front and rear screeds, it can be adjusted by just a flick of a switch.

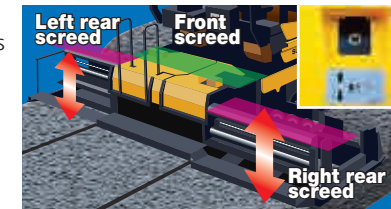

Center crown

The slope from center to side can be adjusted by a switch on the hydraulic crown device.

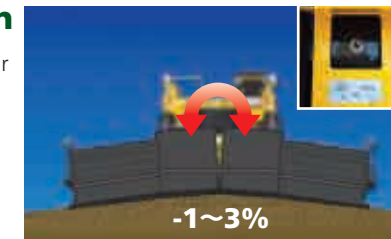

STV compaction system

The adjustable "Strike-off" guides the asphalt mixture smoothly under the screed, and the "Tammer" and "Vibrator" achieve strong and even compaction for pavements with smoothly finished surfaces and superior densities.

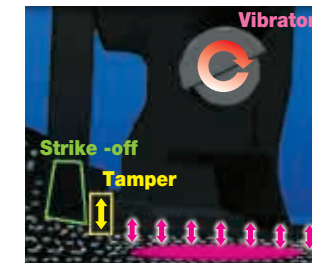

Easy assembly auger system

Work on paving widths up to 7.5 m with the support-free auger system to drastically reduce assembly time.

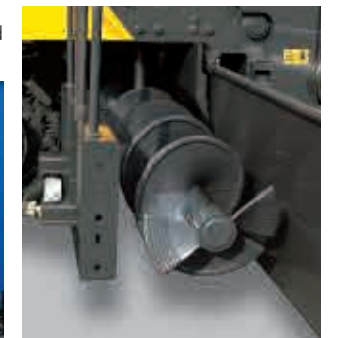

Automatic screed lock

When the automatic lock device is activated, the screed lift cylinder prevents (holds) the screed from sinking into the surface when the machine stops.

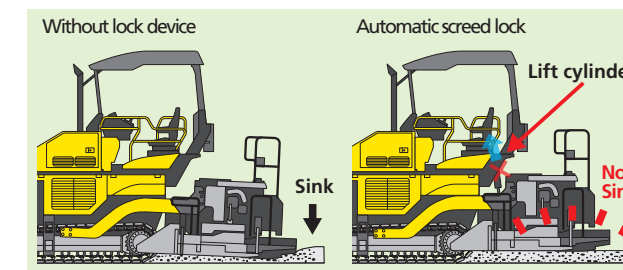

Screed assist

When paving thick layers, the screed lift cylinder assist floating of the screed by the back pressure.

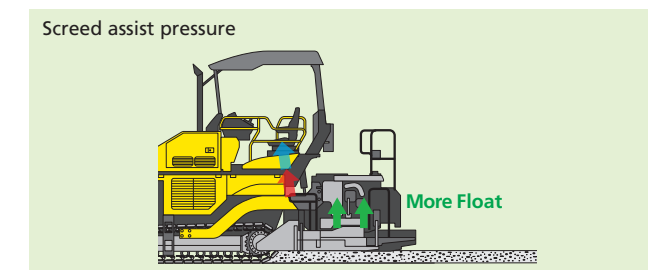

Free: → Pressure: → Lock (hold): X

Labor-saver Feeding System for Best Efficiency.



Low front and large hopper

The hopper's leading edge is low to suit dump trucks with low bumpers. The hopper also has ample supply capacity (13.9 t).



Individual operating hopper wings

This function is useful to avoid obstacles on the road. Operation that also depends on the volume of materials is possible.



Hydraulic operated front apron

The hopper front apron is operated by two hydraulic cylinders, which keeps material inside the hopper and prevents it from spilling onto the ground.



Reversible auger conveyor

A perfect balance of materials in front of the screed can be achieved by this function.



Oscillating push roller

When paving a curved road, the push roller is contacting the tire of the dump truck constantly.



Hydraulically adjusted auger (option)

The height of the auger can be adjusted freely according to the paving thickness. (Adjustment range; 100 mm-250 mm *from the bottom of the auger to the ground)

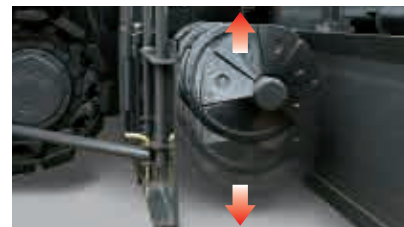

Eco-friendly and repair-friendly

High-rigidity screed

The J-paver screed is capable of consistently stable paving operations.

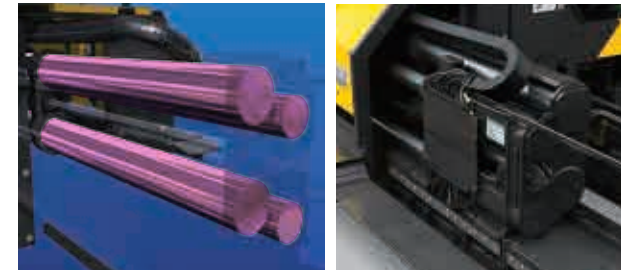

Side plate (end plate)

The slim shape of side plate allows immaculate paving close to the wall.



Extendable mold board

The extendable mold board cuts off the material to avoid excess capacity in front of the rear screed, and it can carry the material smoothly to the end of screed.

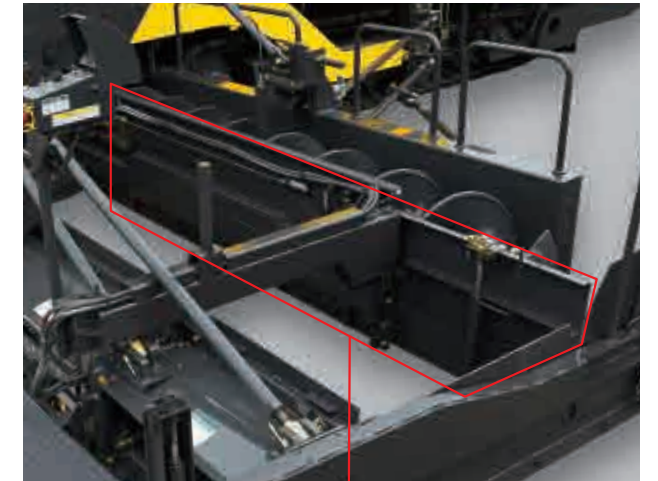

Extendable mold board

Movable control box

The control box can be moved from left to right to provide the operator with greater flexibility.



Eco Mode switch

The Eco Mode switch drops the engine speed from 2,000 min⁻¹ to 1,800 min⁻¹ under light loads, which is effective at reducing fuel consumption.



Eco Mode switch

Slide out seat and control box

The slide out seat is useful for checking the road and working conditions. The control box can also slide to suit the seat. The deluxe suspension seat also adds a higher level of comfort.



Emergency controls

Sumitomo machines are equipped with many emergency control systems. Sumitomo's concept is to continue paving where possible, or in the worst case, move the machine to a safe place away from the road.

Failure device	Functions					Emergency operation
	Travel		Paving			
	High speed	Low speed	Manual	Auto(sensor)	Heating	
Main panel switch and dial	×	○	○	○	○	Operate by monitor
Main panel controller	×	○	○	○	○	Operate by monitor
1 Machine controller	○	○	○	×	×	Replace controller cable
2 Machine controllers	○	○	×	×	×	Replace controller cable
3 Machine controllers	×	○	×	×	×	Operate by emergency mode (main panel controller)

The Latest Traveling Control System with Powerful Towing Capacity.

Jpaver

HA90C-2
EU Stage III A / EPA Tier 3
HA90C-2B
EU Stage III B / EPA Interim Tier 4



Photo of 7.5 m width
Photo may include optional equipment

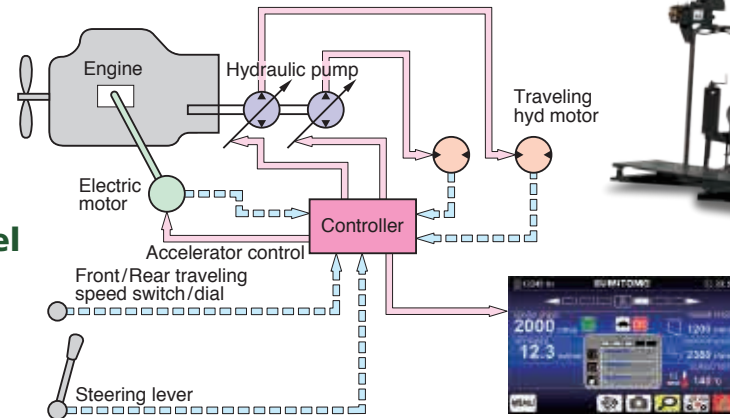

Adopting the latest travel control system

The engine, hydraulic pumps, and traveling motor are centrally controlled with fine precision by the computer. In addition, settings are stored in the computer's memory, so paving can be carried out simply by turning the traveling switch to "on" or "off". Sumitomo's latest feedback system delivers superior traveling stability (by maintaining the set speed and course).

Color monitor

The liquid crystal color monitor displays useful information and can adjust many functions. These simple toggle switches have been used which allows them to be replaced individually with ease.



Sub color monitor

Sub color monitor is equipped on both sides of the extendable screed.



Superior steering function

The spin turn function makes it possible to turn on the spot, which is very useful on cramped job sites such as dead ends.

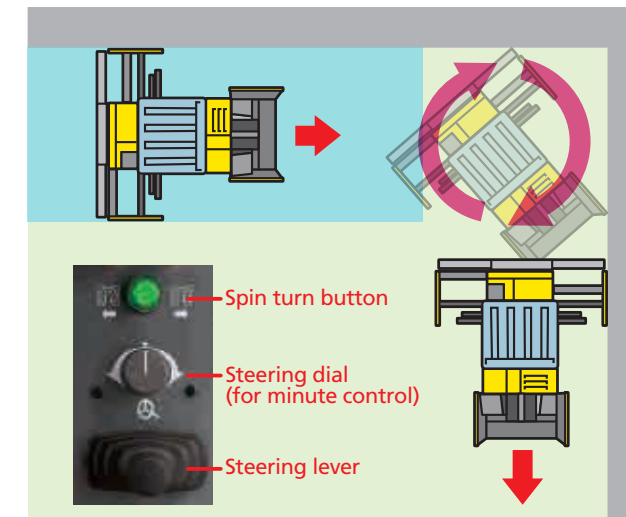

Smooth steering with computerized control

The machine is automatically controlled, with left and right side traveling speeds being set to curve in a continuous smooth arc without losing traction force.

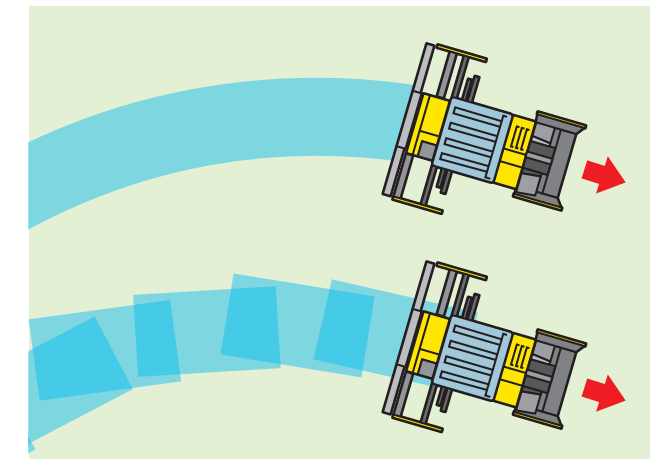

Utilization of a link-shoe with durable rubber pads

The durable rubber pads are equipped on the link-shoe, so asphalt surface is not damaged.



In-shoe motor

The drive motors are mounted inside the shoe and connected directly via sprockets, eliminating chain backlash. This design ensures strong road surface traction capabilities.



Easy maintenance

Daily inspections are extremely straightforward. Oil and grease checks, filter changes as well as other maintenance jobs can be easily carried out just by opening the covers.

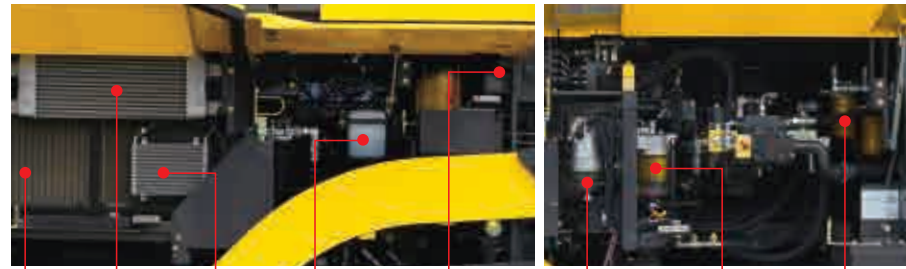

Radiator Intercooler Fuel cooler Reservoir tank Battery switch Fuel filter (main) Fuel pre-filter Hydraulic oil filter



Standard equipment



Screw guard Rear LED auxiliary lighting Traveling indicators Hard top (FRP) canopy

Option



Auto greasing system Crawler blade Hydraulic extendable mold board (in & out)

Grade and slope sensor (option)

The grade sensor is used for leveling screed along a height reference. The slope sensor serves to control the cross-slope of the screed.

Material flow sensor (option)

The material flow controller is used for keeping the material volume in front of the screed.

Sensor type	Feature
① Contact type grade sensor	For direct tracing of a reference (stringline, ground).
② Digi-rotary grade sensor	Same as No. 1. This can be easily operated by "Digital controller".
③-1 Ultrasonic type grade sensor	Non-contacting tracing of a reference (stringline, ground).
③-2 Big-ski	Three ultrasonic sensors scan the reference in non-contacting operation.
④ Digi-slope sensor	This is used with No. 2 or No. 3. This can be operated by "Digital controller".
⑤ Slope sensor	This is used with No. 1.
⑥ Material flow sensor	This is used for controlling the auger speed (The contact type of the conveyor sensor is standard).

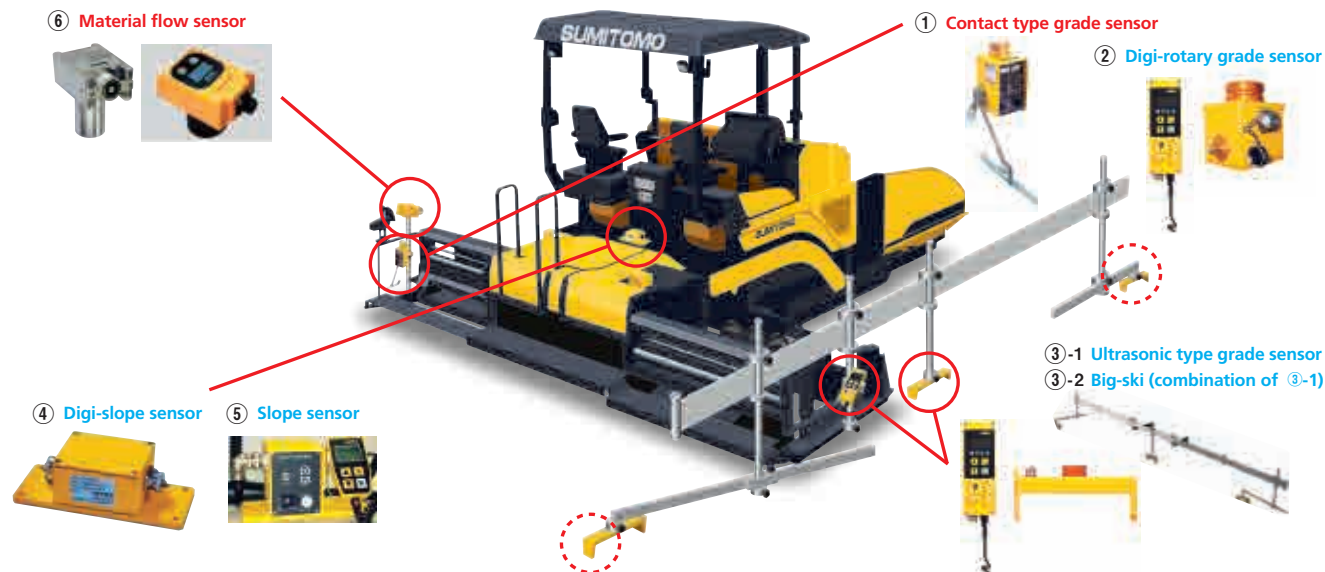

Principle Specifications

		HA90C-2(B) + JP2875	HA90C-2(B) + JP2360	
Paving width	Standard(infinitely variable)	2.8~7.5 m	2.3~6.0 m	
	With extension screed (bolt-on)	9.0 m	—	
Paving performance	Paving thickness	10~300 mm		
	Paving speed	1.5~20 m/min		
	Hopper capacity	13.9 ton		
	Center crown ratio / Side slope ratio	-1~3 (hydraulic oil)		
Dimensions	Operating weight (LPG heating)	21300 kg (transportation) 22800 kg (with EXT. for 9 m paving)	19100 kg (transportation)	
	Operating weight (electric heating)	21800 kg (transportation) 23300 kg (with EXT. for 9 m paving)	19500 kg (transportation)	
	Overall length	7310 mm	7185 mm	
	Overall (transportation) width	2990 mm	2545 mm	
	Overall height (with canopy)	3860 mm		
	Transportation height (with canopy)	2985 mm		
	Tumbler distance	2975 mm		
	Crawler width	304 mm		
Conveyor system	Type of driving method	Hydraulic (individual left & right)		
	Width x No. of line	400 mm x 2		
	Speed	0~27.0 m/min		
Auger system	Auger dimensions	400 dia. x 330 pitch mm		
	Rotating speed	0~83 min ⁻¹	0~75 min ⁻¹	
Screed system	Model	J-paver2875	J-paver2360	
	Heating system	LPG blower burner / Electric (option)		
	Compaction system	Type	Tamber and vibrator	
		Vibrator frequency	0~50 Hz (3000 cpm)	
	Tamber rotating speed	0~20 Hz (1200 cpm)		
	Height adjustment of extendable screed	Hydraulic		
Height adjustment of extendable mold board	Manual (Option: Hydraulic)			
Drive system	Type of driving method	Crawler (track)		
	Drive method	HST		
	Brake type	Automatic brake		
	Traveling speed (forward / backward)	0~3 / 0~3 km/h		
Engine	Make & model	ISUZU AH-4HK1X		
	Exhaust emission	HA90C-2: EU Stage III A / EPA Tier 3, HA90C-2B: EU Stage III B / EPA Interim Tier 4		
	Displacement	5.193 cc (4CYL.)		
	Rated output	132.1/2000 kW/min ⁻¹ (180 hp)		
	Fuel tank capacity	290 L		
	Electric system	24 V		

HA90C-2(B) + J-paver2875 [Crawler Type] (with optional equipment)

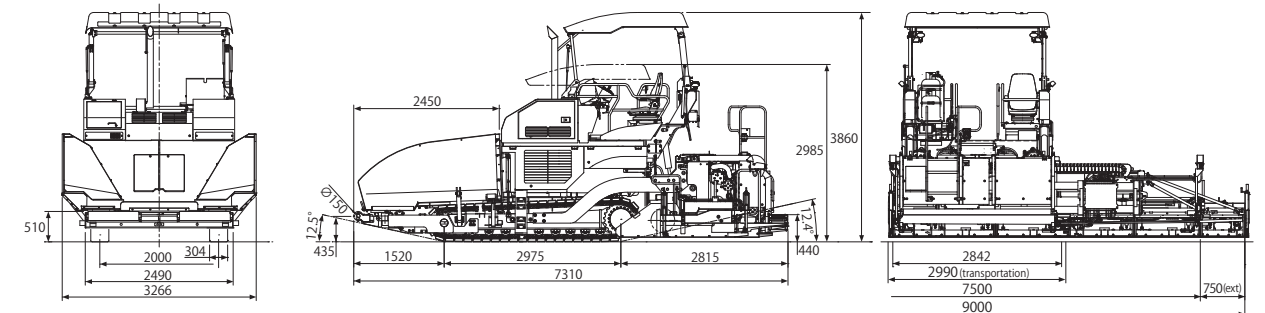

HA90C-2(B) + J-paver2360 [Crawler Type] (with optional equipment)

